

Shuts off Water Supply to taps
Prevents Baths, Basins & Sinks from Flooding
Saves Water and Energy
Requires no electrical supply or maintenance
Automatic reset when taps are turned off

Flood damage from overflowing baths, basins and sinks can be costly. Repairs and replacements are expensive – taking rooms out of use for repairs reduces hotel income. When floods occur in multi storey buildings the inconvenience and costs are multiplied dramatically. Taps left running in baths occurs accidentally – it can also be malicious.

Nova-Flo® is a simple solution to the problem. Out of sight of the bath user, no extra sensors or power supply is needed. It is intuitively self re-setting and maintenance free.

Nova-Flo® has been designed for easy installation and retro fitting using John Guest® Speedfit® plumbing connections. It must be located between the overflow outlet and the waste with adequate fall between them.

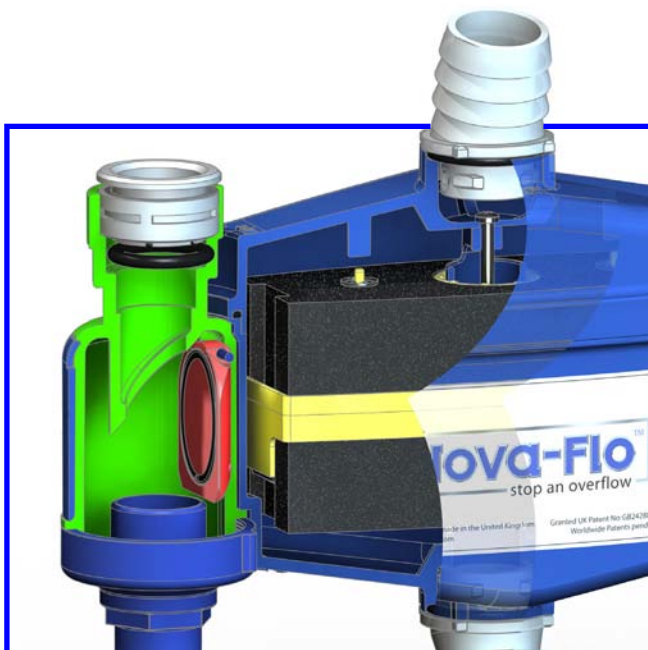

How does Nova-Flo® work?

Nova-Flo® is connected to the overflow pipe between the inlet and the waste trap. The hot and cold supply pipes are connected either side.

When the bath or sink is over filled, water enters the inlet to the overflow pipe and fills the central chamber. A float in the chamber activates a valve that shuts off the supply pipes. While the taps are open, the water pressure keeps the valves in the shut off position.

When the taps are closed and the water level drops below the level of the overflow inlet, the central chamber drains, the float drops and the shut off valves re-open. When the taps are turned on again they revert to full flow.

Efficiency

Nova-Flo® has only three moving parts. It uses no electricity, being entirely mechanical in operation. Resetting the system after shut off is completely intuitive. No user instructions are necessary and, if the installation is hidden by a bath panel, there is no need for anyone to know that a flood prevention device is fitted.

Maintenance and Servicing

Under normal usage conditions Nova-Flo® requires no maintenance or servicing. However it is recommended that a bi-annual check is carried out to confirm correct functioning of the unit. If foreign matter is obstructing the movement of the float in the central chamber then cleaning will be required but access to the chamber is very simple.

Location

Nova-Flo® should be installed in a fixed vertical plane so that the overflow passes through the central chamber by gravity to waste. The hot and cold lines are plumbed in either side of the central chamber. Taps or control valves can be located either before or after the Nova-Flo® unit. Nova-Flo® can be installed before or after a mixer valve and mixed water can pass through one or both of the inlet valves. Nova-Flo® is supplied with 22mm John Guest® Speedfit® fittings on the outflow and straight 22mm stems for push-fit connections on the supply side. The direction of inlet flow is vertically upwards through the unit. Service valves should be installed prior to the unit. Access must be provided so that the unit can be serviced if cleaning is required.



WRAS
0812083
APPROVED
PRODUCT

Dimensions (mm)

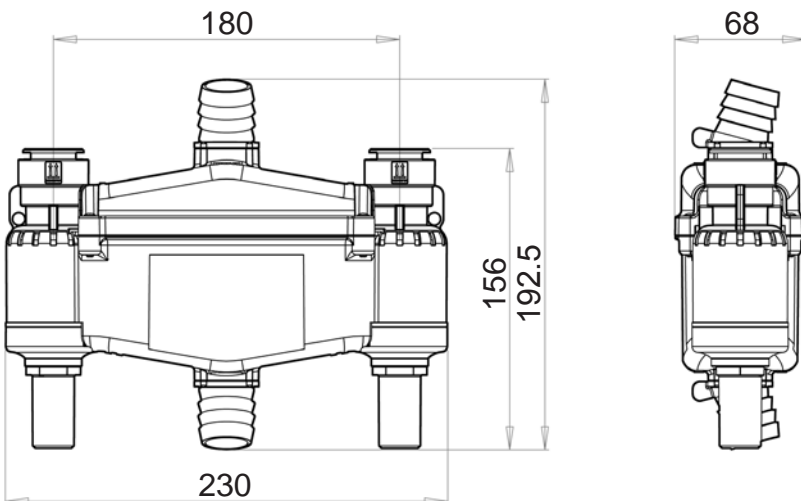

Pack size 300 x 260 x 76.

Weight: 350 grams.

Operating Parameters

Water Pressure:

Maximum Static	8 Bar
Maximum Working	12 Bar
Minimum	1 Bar

Flow Rate:

Maximum 70 Litres per minute per inlet

Water Temperature

Maximum	60°C
Minimum	4°C

Nova-Flo® is supplied with two alternative sized overflow and waste connections 22mm and 28mm.

Suggested Specification

An automatic mechanical overflow prevention device shall be fitted to the hot and cold inlet pipes and be activated only by the overflow outlet. To be manufactured by About Time Design Ltd.

Distributed by

Lifescience
Products Ltd

Rangers Lodge
Cornbury Park
Oxon OX7 3HL. UK

020 7793 2260
www.nova-flo.com
sales@nova-flo.com