

### **Shuts Off Water Supply to Faucets Saves Water and Energy • Prevents Tub Floods Requires no electrical supply or maintenance Automatic Reset when Faucets are turned off**

Water that is allowed to go down the overflow of a bath tub is wasted water. Flowban can save that water and the energy that is used to heat it. It can also stop flood damage.

Faucets left running can easily be forgotten and within minutes the water can reach the overflow, a short time later it can be flooding the bathroom! Some people deliberately allow the faucets to keep running so they can continuously top up with hot water. This is very wasteful and can cause flooding as well.

Flood damage from overflowing bath tubs and sinks can be costly. Repairs and replacements are expensive - taking rooms out of use for repairs reduces hotel income. When floods occur in high rise buildings the inconvenience and costs are multiplied dramatically.

Faucets left running in baths occurs accidentally - it can also be malicious. Some overseas guests are used to using 'wet rooms' where an overfilled bath is quite normal. They are not aware of the damage that can be caused.

Flowban is a simple solution to the problem. Invisible to the bath user, it requires no extra sensor to be fitted inside the tub and no power supply to operate. It is intuitively self re-setting and maintenance free.

Flowban has been designed for easy installation using John Guest  Speedfit® push fit connections. It must be located between the overflow outlet and the waste with adequate fall between them.



#### How Does Flowban™ Work?

Flowban™ is connected to the overflow pipe between the outlet from the tub and the waste. The hot and cold pipes are connected to the supply ports either side of the float chamber.

When the water level in the bath reaches the overflow outlet, water enters the central chamber and activates the float. As the float rises, the magnets that are set into each end of the float react with the magnets on the flapper valves in the supply ports. The flapper valves are pushed into the water flow where the water pressure holds them in the shut position.

A trickle of water is allowed to bypass the flapper valve and out of the faucet. The trickle indicates the faucet is still open but the water level will drop and the central chamber drain. This allows the float to revert to its rest position but the flapper valves stay shut, held in place by the water pressure.

Once the faucet is finally turned off, the pressure equalises each side of the flapper valve which is then drawn back to the open position by the magnet on the float. The faucet can now be opened again and full flow will resume.

## Efficiency

Flowban™ has only three moving parts. It uses no electricity, being entirely mechanical in operation. Resetting the system after shut off is simply intuitive. No user instructions are necessary and, if the installation is hidden by a bath panel, there is no need for anyone to know that a flood prevention device is fitted.

## Maintenance and Servicing

Under normal usage conditions Flowban™ requires no maintenance or servicing. However it is recommended that a bi-annual check is carried out to confirm correct functioning of the unit. If foreign matter is obstructing the movement of the float in the central chamber then cleaning will be required but access to the chamber is very simple.

## Location

Flowban™ must be installed in a location where there is access enabling it to be removed in the rare event of it needing cleaning. It must be installed in a vertical plane and be attached to either 1 1/2" PVC or 1 1/2" brass waste pipe. It cannot be installed on a waste with a trip activator passing through the waste pipe. The water supply pipes are connected with flexible hoses using John Guest **Speedfit**® push fit fittings. Female connectors are required on the bottom nipples and male inserts are required on the top. The flow direction must be from bottom to top. The supply lines can be either hot or cold water or pre-mixed. In the latter case the flow should be split below the unit and reconnected above it. If required, only one inlet may be connected. Faucets may be located anywhere on the bath tub as required. The faucet controls can be fitted either before or after the unit.

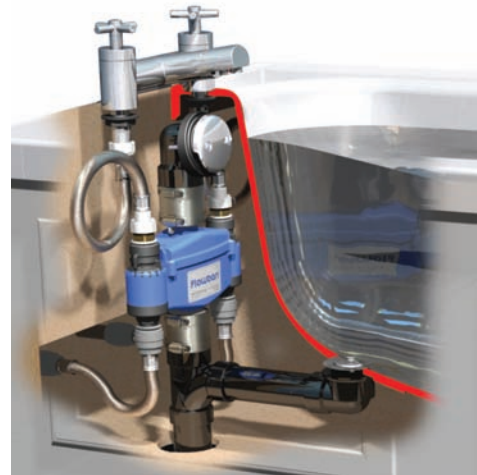

## Sizing in inches

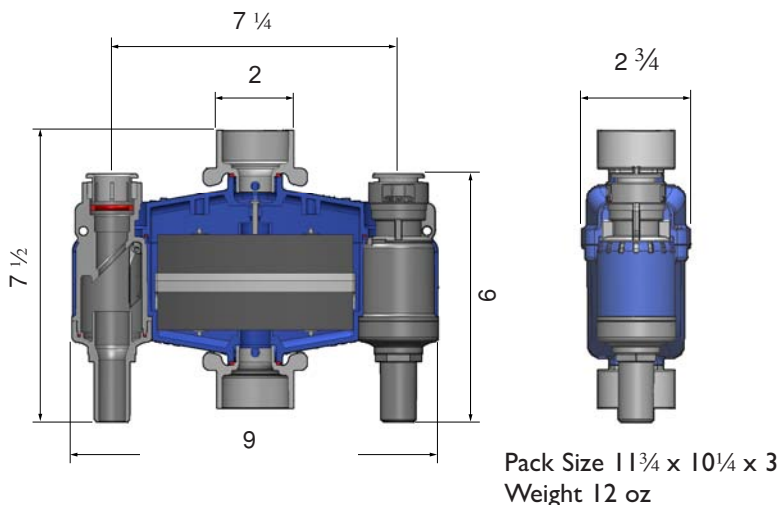

## Operating Parameters

### Water Pressure

Maximum static	8 Bar	115 psi
Maximum working	12 Bar	180 psi
Minimum	1 Bar	15 psi
Maximum flow rate through each inlet port	18 gpm	

### Water Temperature

Minimum	4°C	40°F
Maximum	95°C	200°F

### Recommended fitting accessories.

Brass Wastes :- 2 No. Fernco Proflex 3002-150  
PVC Wastes :- 1 No. Fernco Proflex 3000-150  
and 1 No. Fernco Plumbqwik 1056-150

## Statutory Compliance

Flowban™ is manufactured using Fortron which complies with NSF Standard 61.

Manufactured in compliance with IGC 241 - 2008a Universal Plumbing Code - Model No. NF/FB01



**Flowban Inc**  
**1-877-546-8223**

info@flowban.com www.flowban.com